

---

# SPECIFICATION FOR APPROVAL

Product	DYNAMIC SPEAKER
Part No.	AS-32170B08-A0C
Customer Approval	

Approved By	Checked By	Made By



A & B Components

<http://www.speaker-tw.com>

## 1. SPECIFICATION

AS-32170B08-A0C

ITEM		SPECIFICATIONS	
01	Type	Dynamic speaker	
02	Dimension	External diameter 32 mm	
03	Rated Input Power	2.0 W	
04	Impedance	8 ohm $\pm$ 15% at 1.5K Hz	
05	Resonance Frequency (Fo)	560 Hz $\pm$ 20% at Fo, 1V	
06	Sensitivity (S.P.L.)	74dB(W/m) $\pm$ 3 dB	at AVE 1.0K,1.2K,1.5K,1.8K Hz.
		97dB(2.0W/0.1m) $\pm$ 3 dB	
07	Frequency Range	Fo – 13.8KHz	
08	Total Harmonics Distortion	Less than 8 % at 1 KHz ,1.0V	
09	Max. Input Power	Must be normal at 3.0 W white noise for 1 minute.	
10	Voice Coil	Diameter 13.5 mm	
11	Magnet	Rare earth permanent (Ferrite) magnet $\Phi$ 12.5 x 2.5mm	
12	Weight	32g $\pm$ 1g	
13	Appearance	Should not exist any obstacle to be harmful to normal operation; damages, cracks, rusts and distortions, etc.	
14	Operation Test	Must be normal at program source 2.0W	
15	Buzz, Rattle, etc.	Should not be audible at 4.0V sine Wave between Fo to 20KHz	
16	Polarity	When positive voltage is applied to the terminal marked (+), diaphragm should move to the front.	
17	Terminal Strength	Capable of withstand 1kg load for 30 seconds without resulting in any damage or rejection.	
18	Temperature	Operating temperature: -20°C to +60°C	
		Storage temperature: -30°C to +70°C	

## 2. MEASURING METHOD

### 2-1 .Test Condition

#### STANDARD

Temperature : 15 ~ 35°C

Relative humidity : 45% ~ 85%,

Atmospheric pressure : 860mbar to 1060mbar.

#### JUDGEMENT

Temperature : 20±3°C

Relative humidity : 60% ~ 70%,

Atmospheric pressure : 860mbar to 1060mbar

### 2-2 . Standard Test Fixture

1.Input Power : 2.0W(4.0V)

2.Zero Level : -dB

3.Mode : SPEAKER

4.potentiometer Range : 50dB

5.Sweep Time : 0.5sec

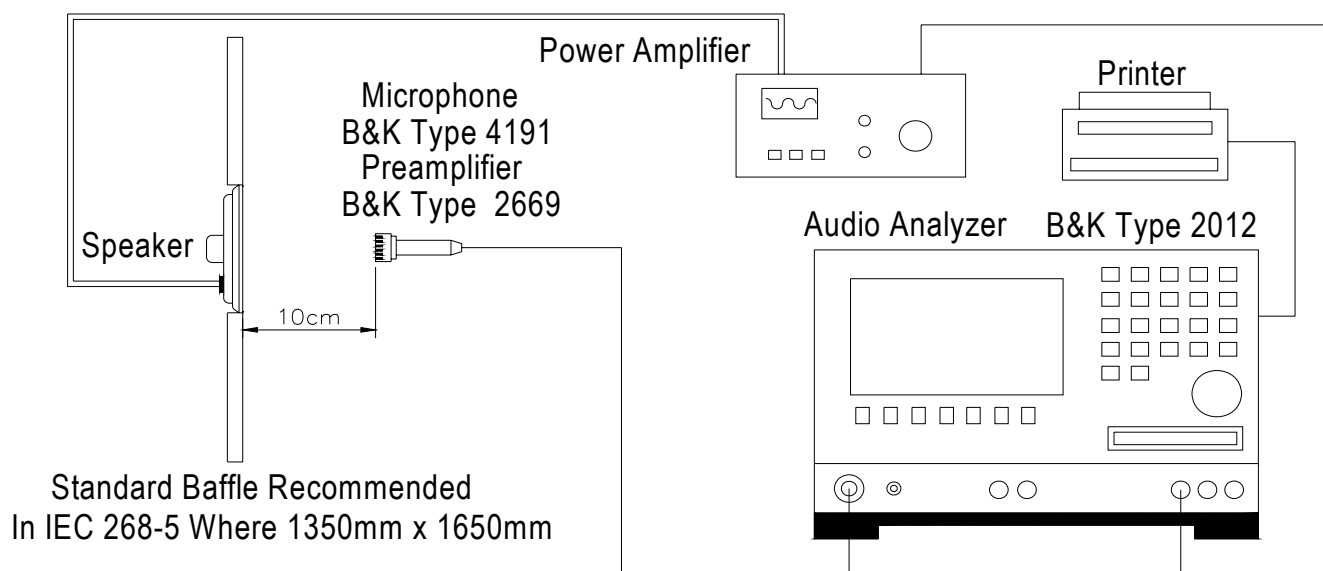

## 2-3. Frequency Response Curve

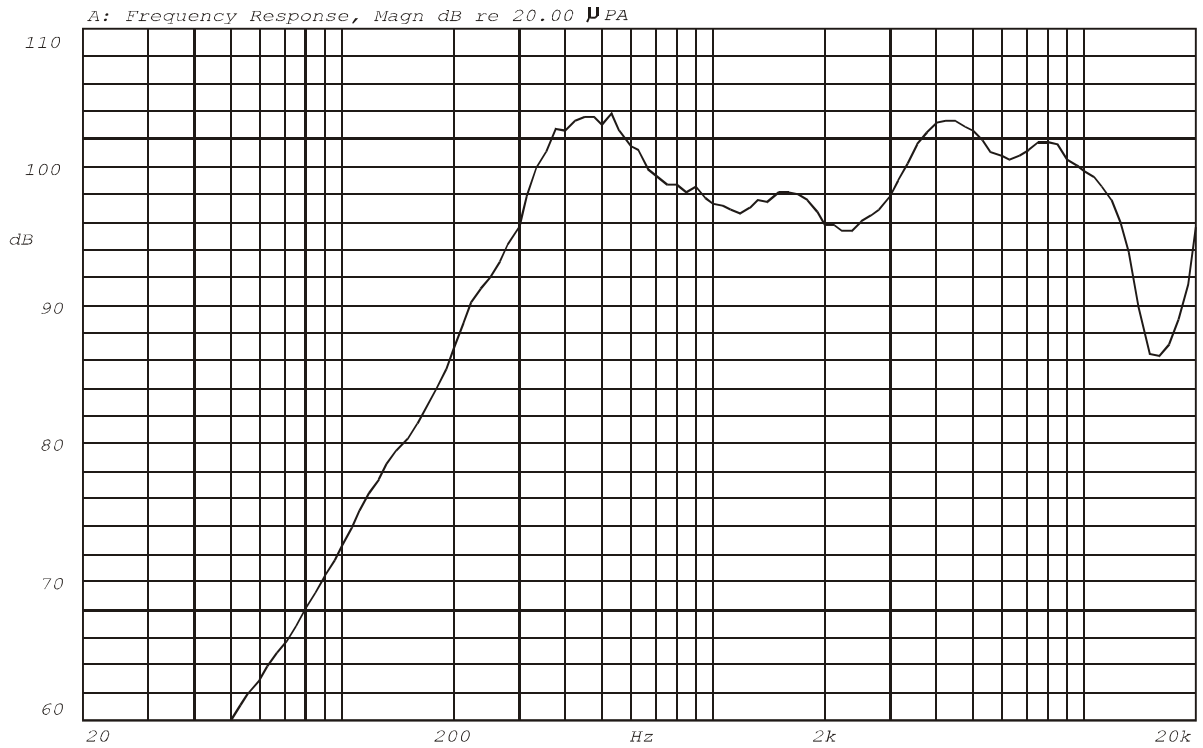

Mode: SPEAKER



## 2-4. Impedance Curve

IMPEDANCE MEASUREMENTS: Measurement of Impedance  $Z(j\omega)$   
X: 560.00HzZA: Liv $\alpha$ : 0.3r30 Impedance  $\Omega$

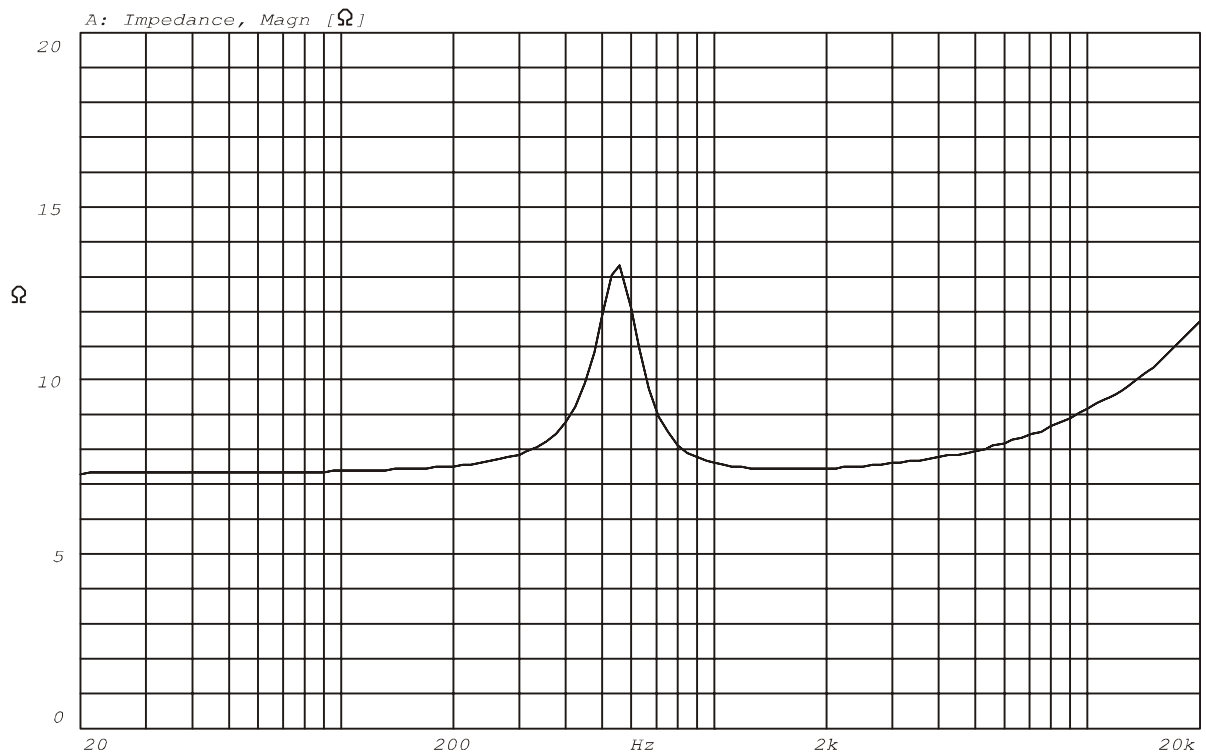

Node:  $Z(j\omega)$



REV NO.	REVISION NOTE	APPROVAL	DATE
---------	---------------	----------	------

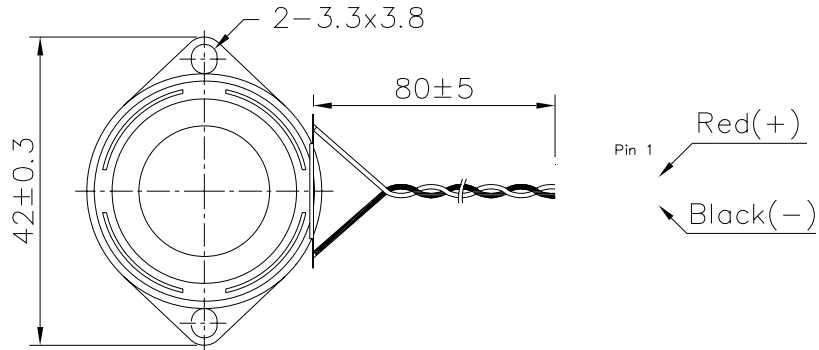

WIRE : UL1571 , AWG28  
CONNECTOR : JST XHP-2 Capable.

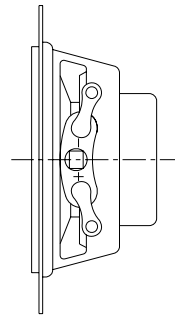
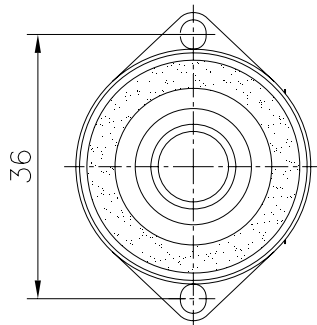
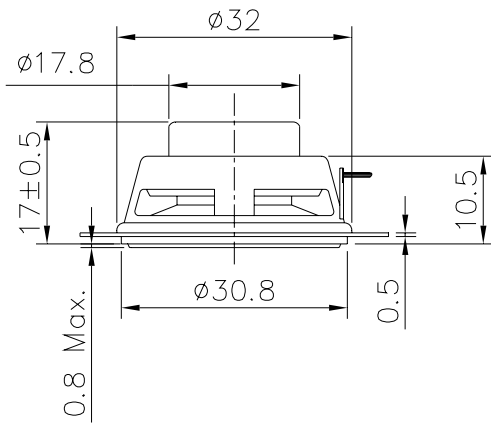

TITLE:	DYNAMIC SPEAKER	DRAWN:	Richard 03/06/2006	SCALE:	1:1	SHEET:	1 of 1
PART NO.	AS-32170B08-A0C	DESIGNED:	R&D DEP.	UNITS:	mm	TOLERANCE	± 0.2
DWG NO.	DTS-1267	1 REV	CHECKED:	UNLESS OTHERWISE SPECIFIED:			
			APPROVAL:	ONE PLACE DECIMAL ± ***			
			MATERIAL:	TWO PLACE DECIMAL ± ***			
			*****	THREE PLACE DECIMAL ± ***			

A & B Components

### 3. RELIABILITY TESTS

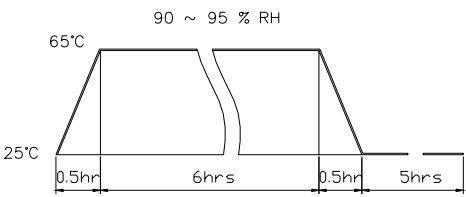
Items.		Specifications
01	High temp. Test	Keep 96 hours at $+70^{\circ}\text{C}\pm 3^{\circ}\text{C}$ and leave 3 hours in normal temperature and then check
02	Low temp. Test	Keep 96 hours at $-20^{\circ}\text{C}\pm 3^{\circ}\text{C}$ and leave 3 hours in normal temperature and then check
03	Humidity test	Keep 96 hours at $+60^{\circ}\text{C}\pm 3^{\circ}\text{C}$ relative humidity 95% and leave 3 hours in normal temperature and then checked.
04	Temp./Humidity cycle	<p>The part shall be subjected 5 cycles. One cycle shall be 12 hours and consist of;</p>  <p style="text-align: center;"> <math>65^{\circ}\text{C}</math>  <math>90 \sim 95 \% \text{ RH}</math>  <math>25^{\circ}\text{C}</math>  <math>0.5\text{hr}</math>   <math>6\text{hrs}</math>   <math>0.5\text{hr}</math>   <math>5\text{hrs}</math> </p>
05	Thermal cycle test.	Low temperature: $-40^{\circ}\text{C}\pm 3^{\circ}\text{C}$ , temperature: $+70^{\circ}\text{C}\pm 3^{\circ}\text{C}$ , cycle: 1 hour/cycle each, and then keep 5 cycles in a room.
06	Vibration	10~200~10Hz sin-wave sweep 15min. 5G(constant) X,Y, Z 3 direction. 2 hours each, total 6 hours.
07	Fix drop test	Fix on jig. Then drop from 152cm height to the concrete floor X,y, z 6 direction. 5 times each, total 30 times.
08	Free drop test	Free drop from 100cm height to the concrete floor X,y, z 6 direction. 1 times each, total 6 times.
09	Load test	Rated Power White noise is applied for 96 hours
10	Max Power test	Max power 1 min on – 2 min off 10 cycles.
11	Terminal strength test	Capable of withstand 1kg load for 30 seconds without resulting in any damage or rejection.